

# BUYER'S GUIDE

FOR THE INDUSTRY'S LARGEST SELECTION  
OF INTERMEDIATE BULK HANDLING AND  
PORTABLE CONTAINER SYSTEMS

LIQUIDS

POWDERS

SOLIDS



**Sii** **SNYDER**  
INDUSTRIES, INC.  
SOLUTIONS IN BULK HANDLING

[www.snyderibcs.com](http://www.snyderibcs.com)

# S Q U A R E   S T A C K A B L E

The industry's best selling, all poly IBC provides an unparalleled value in long-term reusable IBC applications for both hazardous and non-hazardous commodity liquids.

**2" replaceable bung** openings for top draw tube or pressure relief device installation.

**UN and D.O.T. certified** (UN31H2) for Packing Group II and III materials per Title 49 CFR.

**6" HD screw cap** with security tether and automatic vacuum relief vent.

**1/2" thick high density polyethylene** construction provides superior impact strength and corrosion resistance.

**Unique top rib design** protects top ports from impacts, and helps align stacking position.

**Tamper evident bolts** can be sealed to provide greater package security.

**Standard Black HD Base** provides 30% more bottom tank surface protection and large forklift channel pockets reduce the probability of fork damage.



Company logos & product information can be permanently molded in to tank walls.

**Proven 2" bottom drain valve connection** provides virtually complete drainage.

**Four way forklift and two-way pallet jack** access on premium base with anti-teeter pockets on the front and back.



## New! Wide Mouth Square Stackable

**Large lid opening** option facilitates mixing or agitating of liquids and cleaning, sanitizing or drying of the tank interior.



Non-UN/DOT applications only.



Snyder IBC pallets are available in different configurations and colors to meet a variety of application requirements.

Square Stackable				
Capacity Gallons	Tare Weight	Length	Width	Height
330 Premium	267 lbs.	45"	45"	63 1/2"
330 HD	244 lbs.			59"
275 Premium	244 lbs.	45"	45"	56"
275 HD	221 lbs.			51 1/2"
220 Premium	220 lbs.	45"	45"	48 1/2"
220 HD	197 lbs.			44"
150 Premium*	199 lbs.	45"	45"	39 1/2"
150 HD*	176 lbs.			37 1/4"
120 Premium	192 lbs.	45"	45"	36 1/2"
120 HD	169 lbs.			34 1/4"

\*minimum order requirement.

Test pressure: 14.7 P.S.I.G. • Material weight rating: 1.9 specific gravity  
Stacking capacity is 2-3 units high (depending on container size, weight and temperature exposure).

Note: All dimensions and tare weights are approximate.



WWW.SNYDERIBCS.COM

# ULTRATAINER

The ultimate in safety and durability. Ultratainer combines the superior structural integrity of a cylindrical tank with the material handling benefits of a square IBC.

**Optional retractable lifting lugs** offer superior top-lifting capability with crane-hook attachments.



**Multiple Top Port Options**, including 6" screw cap, three (3) 2" bungs, and 20" screw lid.

**Top protector** helps align tanks in stacked position and protects top openings from potential impacts.

**Company name and/or product information** can be permanently molded into top protector.

AVAILABLE WITH A 20" WIDE MOUTH LID OPENING



**Cylindrical inner tank** provides superior structural integrity that eliminates side wall bulging.

With standard 22" threaded lid and gasket, Ultratainer is UN/DOT certified for applications requiring more access to tank interior for mixing, cleaning or drying.

**One piece base and stacking frame** carry load when containers are stacked, which reduces stress on inner tank.

**Four-way forklift and pallet jack** access with optional Anti-teeter bars standard front and back.



**Domed bottom** with standard 2" ball valve provides optimum drainage for most materials.

UN/D.O.T. certified (UN 31H1) for Packing Group II and III per Title 49 CFR.

Patent #5,490,603

**Heavy Weight Ultratainer**, tested at 62 psi or 428 kP for hazardous materials with higher pressure requirements. Available with the innovative design features of the Ultratainer, including top lifting lugs.

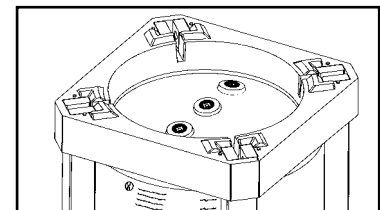

Top configuration with 3 - 2" bungs.

Ultrapure option also available.

Ultratainer				
Capacity Gallons	Tare Weight	Length	Width	Height
330 Ultra	309 lbs./369 lbs. HW	46"	46"	70"
330 Wide Mouth	342 lbs.			
275 Ultra	289 lbs./341 lbs. HW	46"	46"	62"
275 Wide Mouth	321 lbs.			
220 Ultra	268 lbs./313 lbs. HW	46"	46"	54"
220 Wide Mouth	299 lbs.			

Test pressure 14.7 P.S.I.G. • Material weight rating: 1.9 specific gravity  
 Stacking capacity is 2-3 units high (depending on container size, weight and temperature exposure).  
 Heavy Weight (HW): Test pressure: 62 P.S.I.G. • Material weight rating: 1.9 specific gravity  
 Stacking capacity is 3-4 units high (depending on container size, weight and temperature exposures).

Note: All dimensions and tare weights are approximate.



# Excalibur<sup>2</sup>

A low cost and maintenance free reusable alternative to caged IBCs..



6" Heavy Duty Cap

Stacking lugs – help align and secure containers in stacked position.

Proprietary company or product logos can be permanently molded within container wall.

Unique replaceable foot design is similar to stainless steel IBC legs, but can be replaced, if ever damaged.

2" bottom drain valve with quick disconnect; Also, available with check (one way) valve options.

Snyder automatic vacuum relief vent enables container to drain freely during discharge (not for pressure venting).

(Optional) 2" replaceable bung closure is available with buttress and NPS thread that can be easily replaced, if ever damaged.

UN/DOT Certified (UN31H2) for Packing Group II and III materials per title 49 CFR.

Four-way Fork-lift and Pallet jack entry-allow containers to be easily accessed from all directions.

100% HDPE, thick wall construction provides maximum corrosion and chemical resistance.

Patent # 6,484,899



EXCALIBUR <sup>2</sup>				Patent Pending	
Capacity Gallons	Tare Weight	Specific Gravity	Length	Width	Height
120	96 lbs.	1.35	42 1/2"	42 1/2"	32 1/4"
250	126 lbs.	1.35	42 1/2"	42 1/2"	48 1/4"
330	176 lbs.	1.35	47"	47"	52 1/8"
250	175 lbs.	1.9	42 1/2"	42 1/2"	32 1/4"
330	220 lbs.	1.9	47"	47"	52"

Note: Test pressure: 14.7 PSIG. Standard with 1 - 2" Sii Automatic Vacuum Vent EPDM located in the center of the 6" HD cap. Optional 2" replaceable bung fill port with bung plug opposite of the 6" Cap. All dimensions and tare weights are approximate.

EXCALIBUR					
Capacity Gallons	Tare Weight	Specific Gravity	Length	Width	Height
120	82 lbs.	1.35	31"	42"	36 1/4"

Note: Test pressure: 14.7 PSIG. Standard with 6.5" GEM Cap and 2 bungs. All dimensions and tare weights are approximate.



# MEGATAINER

Versatile and lightweight, the industry's largest poly-IBC system offers dependable transportation of bulk chemicals with reduced shipping and handling costs.



Patent # 6,079,580



(optional)  
Megatainer and other Snyder IBCs can be mounted to a trailer with non-regulated or exempt applications and be directly discharged from a motor vehicle without having to move the container itself.

**Top Lifting Lugs - (optional)** This unique top-lifting component package enables the Megatainer to be easily lift by crane and hoist equipment.

Megatainer				
Capacity Gallons	Tare Weight	Length	Width	Height
550	572 lbs.	81"	48"	60"

Material weight rating - 1.9 specific gravity. Test pressure: 14.7 PSIG.  
Stacking capacity 2-3 units high depending on material weight and temperature exposure. Note: All dimensions and tare weights are approximate.

## Features for both models include:

**2" replaceable bung** opening for accessory installation (draw tube, pressure and/or vacuum relief vents, stacked discharge receiving connections, etc.).

**Stacking alignment lug** assures containers are stacked securely and that the load is transferred properly.

**Structural rib design** provides unparalleled container strength and durability for all handling applications.

**Unique Horizontal Design** shape creates low profile container with easy access to top ports.

**4-way forklift and pallet jack** accessibility makes container handling versatile and convenient.

**UN/D.O.T. certified** (UN 31H2) for Packing Group II and III per Title 49 CFR.

(Option) **MSDS/Placard holder** protects documents from the elements.

**Megatainer LX** offers the same benefits as the standard model but without the lifting feature - as a lower cost alternative.



Megatainer LX				
Capacity Gallons	Tare Weight	Length	Width	Height
550	542 lbs.	81"	48"	60"

Material weight rating - 1.9 specific gravity. Test pressure: 14.7 PSIG.  
Stacking capacity 2-3 units high depending on material weight and temperature exposure. Note: All dimensions and tare weights are approximate.



# DOUBLE WALL IBCs

A tough, stackable triple-wall reinforced and insulated all poly 330 gallon container for a wide range of chemical applications.

## Payloader 330 DW

**Rugged all polyethylene double wall construction** provides superior strength and impact resistance.

**Frame cavity is insulated with polyurethane foam** for temperature sensitive liquids.

**Protected and secured discharge** in a recessed area protected by a sliding gate.

**Tapered bottom with unique patented discharge system** with 2" ball valve attached to molded spout.\*



Manufactured from food grade polyethylene.

Space saving stackable design.

UN/D.O.T. certified (UN 31HH1) for Packing Group II and III per Title 49 CFR.

4-way fork-lift or pallet jack operation.

Payloader 330 DW				
Capacity (Gals/Liters)	Tare Weight (lbs./Kg)	Length	Width	Height
330/1250	331/147	48"	45"	65 1/4"

\* Note: All dimensions and tare weights are approximate.

A unique complete drainage system. The 2" valve seals the drain spout using a split ring collar. A bracket supports the recessed valve to the tank. The valve can be locked in the closed position to prevent accidental discharge.

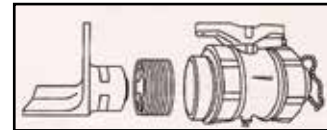

## The Deuce



The Deuce			
Capacity Gallons	Tare Weight	Dimensions WxDxH	S.G.
180	304 lbs.	43 1/2" x 49" x 36"	2.0
330	459 lbs.	43 1/2" x 49" x 57 1/2"	2.0

Note: All dimensions and tare weights are approximate.

- Heavy-duty polyethylene bottle enclosed in a 3/8" thick polyethylene secondary containment.
- 330 gallon Deuce meets **UN/D.O.T. certified** (UN 31H1) for Packing Group II and III per Title 49 CFR.
- UN/D.O.T. certification for 180 gallon Deuce is available upon special request.
- 7" screw cap with heavy-duty buttress threads.
- Contains stacking leg positioners for secure stacking two high.
- Available in 180 and 330 gallon sizes.
- Molded four-way forklift entry.
- Sloped bottom assists in complete product drainage.



# COMPOSITE IBCs

Combine the strength of steel with the versatility of plastic to meet certain application requirements.

## 330 Gallon Dual Tank Transporter

Two (2) 165 gallon polyethylene tanks side by side in one pallet frame for delivery of two fluids in one IBC package!

**2" Replaceable Bungs** can be used for top draw applications or installing other fitting and accessories, and can be easily replaced, if damaged, without having to replace the entire tank.



**2" automatic vacuum vent** is the only all plastic design of its kind, which provides maximum corrosion resistance and optimum vacuum relief compared to spring loaded devices.

**4-Way Jack and Forklift Accessibility** with standard anti-teeter bar for safe, stable handling.



**DOT UN31HA1W APPROVED** for shipment of compatible multiple materials, which may not generate explosive, flammable, or poisonous gases if mixed. (Reference CA2015030032)

**Integral Lifting Eyelets** enable container to be lifted overhead by a crane or hoist and help align and secure containers in a stacked position.

**3/8" Thick Polyethylene Tanks with Reinforced Top Tank Design** resists inward warping common in other caged IBC designs, and eliminates any recessed areas to collect or pool rainwater or overflow liquids.

Available with or without bottom discharge valve.

- **Without valve** - optional draw tube with sloped bottom enables full discharge.
- **Proven 2" bottom discharge valve connection per tank** provides optimum drainage for most liquids.

**Note: All dimensions and tare weights are approximate.**



### Dualtainer™

Capacity (Gals/tank)	Tare Weight	Length	Width	Height
330/165	605 lbs.	48"	40"	63"

Overall dimension of frame at foot is 50.9" x 42.9" Note: Test pressure: 14.7 PSIG. Material rating 1.9 S.G.



### CageMaster™

Capacity Gallons	Tare Weight	Length	Width	Height
220	475	48"	40"	52 5/8"
330	550	48"	40"	66 1/8"

- **UN/D.O.T. certified** (UN 31HA1) for Packing Group II and III per Title 49 CFR.
- Replaces Econo Model. (Note: Will stack on Econo tank but Econo tank will not stack on CageMaster).
- Interstacks with similar Cage style models in US.
- Bottle/pillow sets and/or frames are interchangeable as replacement components for competitive Composite Asset IBCs.



Note: Test pressure: 14.7 PSIG. Material rating 1.9 S.G.



# SUPERTAINER

The industry standard for steel IBCs. Snyder Supertainers are constructed of 10 gauge steel with the industry's most sophisticated manufacturing process.



## Supertainer Standard 42" x 48" Base Tanks

Tank Size - Gallons	Approx. Tare Weight	Top Head Dimension	Overall Height
120	302 lbs.	21.25"	24.6"
126	315 lbs.	23.25"	26.6"
165	326 lbs.	26.25"	29.6"
180	340 lbs.	29.25"	32.6"
245	389 lbs.	35.25"	38.6"
300	424 lbs.	41.25"	44.6"
350	469 lbs.	47.25"	50.6"
446	542 lbs.	59.25"	62.6"
550	612 lbs.	71.25"	74.6"

## Supertainer 42" x 48" Base, Center Drain Tanks

350 Gallon	601 lbs.	49.50"	52.9"
550 Gallon	757 lbs.	73.50"	76.9"
550 Gallon TRU-Center	768 lbs.	76.50"	79.9"

## Supertainer 54" x 54" Center Drain

793 Gallon TRU-Center	1010 lbs.	76.50"	79.9"
-----------------------	-----------	--------	-------

## Supertainer Standard 42" x 42" Base Tanks

Tank Size - Gallons	Approx. Tare Weight	Top Head Dimension	Overall Height
140	297 lbs.	26.25"	29.6"
160	310 lbs.	29.25"	32.6"
220	356 lbs.	35.25"	38.6"
250	388 lbs.	41.25"	44.6"
300	430 lbs.	47.25"	50.6"
390	498 lbs.	59.25"	62.6"
446	562 lbs.	71.25"	74.6"

*Additional Options: Sanitary Designs; Center Drain with fork channels; Custom Designs.*

**Note:**

*All Center Drain tanks come with 2-way fork channels as standard, but can be removed if needed.*

*All approximate weights provided are based on stainless steel materials.*

*Other tank sizes and custom base sizes are available.*





# SUPERTAINER

*Robotic manufacturing process ensures consistent high weld quality and assurance of container integrity.*

**22 5/16" cover with EPDM Gasket and 2" Rieke Fusible Vent/or 3" fusible vent, so cover can remain sealed during filling. 2" bung fitting optional.**



**2" flush mounted bung fitting.**

**Lifting Lugs** enable container to be lifted overhead via hoist or crane apparatus.



**10 Gauge material construction on tank heads and shell.**

**Available in 304, 316 stainless or painted carbon steel for optimum durability and corrosion resistance.**

**Unique Stamped Bottom** provides "no heel" bottom for total drainage.

**3 Way Fork Entry** for both pallet jack and forklift access.



**DOT UN31A** permits shipment of flammable and combustible liquids as authorized by Title 49 CFR.

**Multiple valve arrangements** are available to meet different function and connection requirements.

**2" Ball Valve Outlet Assembly.**



**Optional 2" 15° Offset Male Quick Connect Adapter.**

## Valve Configurations

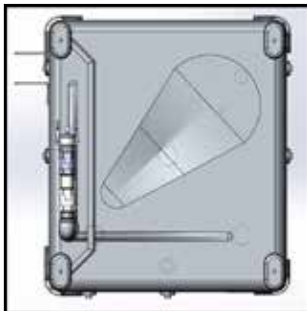

Side Discharge

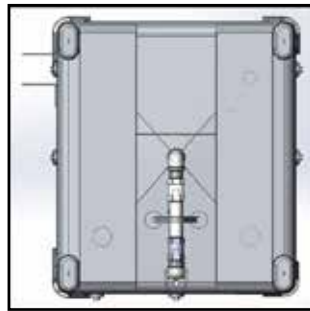

True Center Discharge

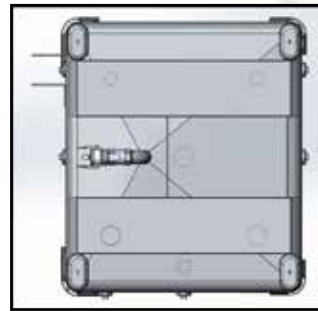

Front Center Discharge

**Temperature control devices can be integrated within an IBC for heating and cooling requirements.**



All Snyder IBCs are available with stacked discharge feed systems that allow the top tank to drain into the bottom tank.



**Cooling/Heating jacket panels** provide temperature transfer surface for chilling, clarification and curing processes.



**Heating Coils:** Lid mounted coil temperature system controls product temperature by steam or water. Cork screw coil w/ protective collar.



Options for sanitary applications.



# VISCOUS LIQUID IBCs

Snyder has a wide array of IBC design types to promote better drain flow of materials with varying levels of viscosity.



- Bolted top design provides weather tight seal.
- Pressure/vacuum vent.
- Translucent bottle allows viewing of product level.
- Flexible follower bag cleans sidewalls as material is discharged.
- Four-way fork tube and pallet jack entry polyethylene pallet.
- Sumped outlet.
- Optional 2" or 3" direct bolt ball valve with adapter, cap and lanyard.
- 1/2" thick rotational molded bottle.
- Gross Max. weight - 4500 lbs.

Poly Visco Drum			
Capacity Gallons	Tare Weight	Diameter	Height
330	398 lbs.	49"	76 3/4"

Note: All dimensions and tare weights are approximate.



Patent #7,475,796

Flowmaster's 45° cone bottom slope helps facilitate faster, more complete flow in the most stubborn viscous liquid applications.

- All Plastic, HDLPE construction complies with FDA, NSF and USDA standards.
- Translucent bottle allows viewing of material levels with level indicators.
- Seamless, smooth interior surface offers excellent flow characteristics and is easy to clean.
- Eliminates corrosion concerns and associated maintenance costs.
- Heavy duty plastic stands are forklift and pallet jack accessible and come in a variety of colors to help designate specific applications.
- 12" screw on cap secures container contents.
- Molded 2" and 3" threaded outlet for camlock type outlet fitting.
- Ball valve can be positioned vertically, horizontally, or at a 45° angle.
- Stackable 2-3 units high depending on size, weight and temperature exposure.



Horizontal 2" valve configuration.

Flowmaster Viscous Liquid Bin			
Capacity Gallons	Tare Weight	Footprint	Height 45° Bin
190	250 lbs.	48" x 48"	56"
300	290 lbs.	48" x 48"	68 3/4"
375	315 lbs.	48" x 48"	76 3/4"
450	335 lbs.	48" x 48"	85 3/4"
600	395 lbs.	48" x 48"	101 3/4"

Note: All dimensions and tare weights are approximate.



# VISCOUS LIQUID IBCs

For non-leveling material such as body sealers, caulking, and similar high viscosity fluids, Viscous Drums are the right choice.



Visco Drum			
Capacity Gallons	Tare Weight	Diameter	Height
379	930 lbs.	45 1/2"	76"

- Flexible follower plates clean sides as material is pumped out.
- 1/4" thick removable top.
- Air chuck and air gauge to allow 3 psi air line to be applied to drum.
- Other custom sizes available.
- Pressure/vacuum relief vent.
- Stacking ring.
- 4 way extended fork tube assembly.
- Sight tube level indicator assembly graduated for convenient monitoring.
- Heavy duty lid assembly includes pressure gauge, gasket, and 3 - 2" openings and 1 - 1" NPT opening.
- Lid and follower easily removed for cleaning.
- 3" Bronze ball valve with quick camlock connect and cap.
- Optional 3" dry break valve available.



Magna Drum			
Capacity Gallons	Tare Weight	Inside Diameter/ Outside Diameter	Height
300	1275 lbs.	42.50"/48.50"	58"

- Ease in emptying/filling viscous fluids.
- Special coating internal lining.
- Optional paint colors available for company or product branding.
- Full open top with lightweight aluminum cover and Rieke emergency vent.
- 3" bottom service fitting with plug.
- Designed to work with positive displacement pumping systems.
- Dimensions designed to ensure precise fit and minimize material waste and container clean-up.



Jumbo Drum			
Capacity Gallons	Tare Weight	Diameter	Height
160	370 lbs.	45 1/2"	38 1/4"
250	440 lbs.	45 1/2"	50 1/4"
330	560 lbs.	45 1/2"	62 1/4"
385	580 lbs.	45 1/2"	70 1/4"
440	600 lbs.	45 1/2"	78 1/4"
500	640 lbs.	45 1/2"	86 1/4"

\*Weights listed are for carbon steel, add 10 lbs. for stainless steel weight.

- Economical steel IBC for commodity liquids.
- Ideal for in-plant mixing.
- Bottom channel provides for complete drainage.
- Flanged top and bottom head with 22 5/16" drum lid opening.
- Stackable up to 2-3 high.
- Discharge outlet has 2" standard stem bronze or stainless steel valve.
- Lifting lugs welded on outer shell.
- Stackable up to 3 high.
- Optional UN/D.O.T available upon special request.



# PLASTIC HOPPER BINS

**NEW!**



## New Closed Top Design

- Tapered top eliminates “pooling” of liquids on the top of the hopper. And,
- New interlocking corner stacking lugs facilitate safe and stable stacking of hoppers.

All Flowmaster hoppers are molded with an extra thick 0.500” heavy duty wall for a longer lasting, more durable container. Molded from High Density Polyethylene (HDPE), the hoppers are corrosion and chemical resistant with superior impact strength and puncture resistance. One piece hopper construction and seamless interior improves material flow characteristics. Flowmaster Plastic hopper bins are available in a variety of design configurations to meet specific dry handling requirements. Choose from Closed Top or Open Top volume capacities of 25 Cu. Ft. to 80 Cu. Ft. and hopper slopes of either 45° or 60° degree angles.

### Standard Sizes:

- 45° hopper angle - 25, 40, 50, 60, and 80 cubic feet.
- 60° hopper angle - 30, 48, 58 and 68 cubic feet
- New improved Sanitary Base with two (2) way fork entry and anti-teeter fork pockets.
  - Optional original base offers four (4) fork entry and two (2) way pallet jacks.
- Closed Top Lid Options
  - 12” threaded cap and EPDM Gasket (solid or vented).
  - 18” Internal threaded cap (solid or vented).
  - 22” Sanitary Drum style lid with 304 S/S clamp ring.
- Available with top stacking/alignment lugs or recessed pockets for secure, stable stacking.
- Standard discharge options:
  - 4” Slide gate or butterfly valve.
  - 8” Slide gate, butterfly valve or Iris valve.
  - 12” Slide gate, butterfly valve or Iris valve.
  - Other sizes available upon special request.
- Optional top lift features:
  - Standard lift
  - Industrial - (available with all lids).
  - Sanitary (only available with 22” Sanitary Lid).
  - Heavy Duty Lift
    - Industrial
- Optional extension legs can be permanently molded and cut to desired elevation clearance up to 48”.
- Proprietary company and product information can be permanently embossed within the container wall.
- Seismic Tie Down Capabilities.
- UN Certified IBC design models available upon special request and volume.
- Other custom sizes available with sufficient volume.
- Complete line of ancillary equipment & accessories.



Standard Closed Top Design

Sanitary Closed Top Design



Open Top Design (non-stackable)



Heavy Lift Bin Design

## Flowmaster Hopper Bins

Capacity	Footprint	Tare Weight A	Height A - 45° Bin	Capacity	Tare Weight B	Height B - 60° Bin
25 C.F.	48" x 48"	250 lbs.	56"	30 C.F.	295 lbs.	70 1/4"
40 C.F.	48" x 48"	290 lbs.	68 3/4"	48 C.F.	330 lbs.	83"
50 C.F.	48" x 48"	315 lbs.	76 3/4"	58 C.F.	360 lbs.	91"
60 C.F.	48" x 48"	335 lbs..	85 3/4"	68 C.F.	380 lbs.	100"
80 C.F.	48" x 48"	395 lbs.	101 3/4"	N/A	N/A	N/A

Other sizes available upon request Note: All dimensions and tare weights are approximate.



# STEEL HOPPER BINS

*Flowmaster steel hopper bins can be designed to exact specifications with customized features for filling and discharging.*

**Four combination stacking pads/leg positioners/lift lugs.**

**Available in designs that meet UN/DOT specifications.**

**Available in 304 and 316 10 gauge stainless steel or carbon steel for optimum durability and corrosion resistance.**

**Extension legs can be modified to accommodate varying bottom clearance requirements.**

**Top head is one-piece stamped construction with large 2" radius corners.**

**22 5/16" top opening with a 16 gauge barrel lid. Other lid options are available upon request.**

**Securely stacks up to 3 high, full or empty.**

**Hopper bins slopes can be configured with different slopes. 30°, 45°, and 60° are the most common.**

**Rugged fork channels allow easy four-way forklift access and can be overhead lifted.**

**Several valve options are available including slide gate, butterfly and iris.**



*Discharge Stations can be designed to provide "dust free" transfer of material from steel and plastic containers into specific processes or packaging systems.*

Flowmaster Steel Hopper Bins		
Capacity	Overall Height	Hopper Angle
30 Cubic Feet	47.50"	45°
45 Cubic Feet	62.25"	45°
62 Cubic Feet	75.00"	45°
78 Cubic Feet	88.50"	45°

*All dimensions in inches and based on 45° hopper with 8" Valve.*

*Other sizes available upon request. All dimensions are approximate.*



## **Optional Electro-Polishing**

*The electro-polishing process assures a non-stick, non-stain and grit free surface for applications requiring superior product cleanliness. The mirror-like surface allows complete product draw-down enabling fast wash down for contamination free storage. Electro-polishing can be applied to the interior and exterior surfaces of stainless steel products.*



# SAF-TAINER

**Protect your company against hazardous IBC spills with the portable, cost effective protection of Saf-Tainer.** It's the most cost effective system on the market today. The unique polyethylene design reduces the risk of unrecoverable spills and protects the environment. It's economical price and versatile design saves you money while safely addressing your company's ever-changing environmental concerns.



**Benefits:**

- Meets 40 CFR 264.175 which satisfies containment regulations.
- 100% polyethylene construction which offers superior corrosion and chemical resistance.
- 485 gallon containment capacity.
- 8000 lb. static load capacity which allows it to handle heavier loads.
- Sump with drain plug making it easy to drain and clean.
- Portable and lightweight allows you to move Saf-Tainer where it's needed.



Drain Plug allows easy emptying and cleaning.



Forklift Channels make Saf-Tainer easy to move and stack.



Saf-Tainer is compatible with all poly IBCs.



8000 lb static load capacity allows stacked discharge arrangements.



Optional top grating makes Saf-Tainer compatible with most IBCs, including metal.



Internal platform can also be used as IBC stand.

## DRUM-PAL - The Most Durable Drum Pallet in the Chemical Industry

A revolutionary pallet design for racking, stacking and transporting chemical drums. Drum-Pal is manufactured from steel reinforced HDPE polyethylene and as a result is extremely durable, chemical and impact resistant, and virtually maintenance free.



**The features include:**

- "Deck-Lok" safety stacking.
- Locators for 55 gallon drums.
- Non-skid top.
- One piece "solid wall molded", internal molded-in steel reinforcement.
- Rackable.
- Stackable.
- Under deck hand hold.
- Side hand holds.
- Conveyor able.
- 48.5" x 48.5".
- Optional steel bar reinforcement for ultra-heavy materials.

Load Rating	Tare Weight	Length	Width	Height
Static/Dynamic: 20,000/3500 lbs.	63 lbs.	48.5"	48.5"	6"

Note: All dimensions and tare weights are approximate.

Drum-Pal is a smooth top, super heavy weight pallet that has the drum locators and a molded in non-skid surface for in-plant work in process or closed loop shipping. Great for stacking one pallet on top of another with fully loaded drums..



# OPTIONS & ACCESSORIES

Snyder's full line of options and accessories helps customize our container products to your company's specific requirements.



**Pressure/Vacuum Vents:**  
2" poly light-duty pressure/vacuum vents are available in different material constructions and pressure ratings to meet a variety of chemical applications.



**Ultra-Pure Connection Points:**  
available in a configuration designed to accommodate the ultra-pure chemical sector's most popular draw and return tube assemblies.



**2" Replaceable Bung with Plug** enables a damaged thread to be easily replaced without having to replace an entire container.



**Placard/Document Holder** (optional) protects enclosed information from the elements.



**Fusible Vents:** are available to provide emergency relief in the case of extreme temperature exposure.

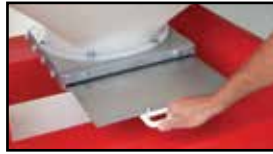

**Dry Material Valves:** are available in a variety of configurations and sizes including: slide gates, butterfly valves, sanitary butterfly valves, iris valves, and more.



**Poly Ball Valves:** Precision molded plastic ball valves are available in many sizes with a multitude of connection and closure options.



**Adapters:** are available in steel and plastic configurations to further accommodate connection and closure requirements.



**HDPE Polyethylene Screw Caps:** are available in multiple configurations with different gaskets and internal closures.



**22 5/16" Barrel Openings** are ideal for gaining greater access to tank interior and are available in both steel and plastic tanks.



**Stainless Steel Valves:** are available in many different designs including: standard, AMI flush mounted ball valve, ball valve, and sanitary butterfly valve.



Standard 2" Ball Valve.  
Other optional sizes available.



Valve Options  
Sanitary, Ball, Butterfly



Quick Connect Adapters



Pressure/Vacuum  
Vents



Drum Lid Clamp Rings  
Bolted & Lever-Lock Styles



3" Fusible Vent



2" Rieke  
Fusible Vent



Crossbar  
Bung Fittings



Lid Gaskets



Drum Lids in 304 & 316  
Stainless Steel & Carbon  
Steel



2" 15° Offset Male  
Quick Connect  
Adapter



3" GITS 5 in 1 Fusible  
P/V Vent



**At-A-Glance Gauge:** Designed for long-life and easy readability the "At-A-Glance" liquid level indicator is available in steel IBCs.





## **DEF STORAGE**

To meet 2010 EPA regulations in North America, most producers of diesel engines have announced plans to use Selective Catalytic Reduction (SCR) technology, requiring Diesel Exhaust Fluid (DEF). Diesel Exhaust Fluid (DEF) is a high purity chemical fluid consisting of 32.5% urea mixed with high purity water. By providing the right kind of storage tank for DEF, safety can be maintained and the integrity of the product can be preserved. Snyder Industries offers single wall and double wall containment designs along with several options and features that make our tank systems ideal for handling your DEF.



## **SINGLE WALL VERTICAL & HORIZONTAL TANKS**

Single wall vertical and horizontal storage tanks with stands available in HDPE or XLPE with containment basins with tank shelf and pump mount brackets for mini-bulk delivery and feed systems.



## **CHEMICAL FEED STATIONS**

Long lasting, corrosion-resistant tank and containment systems that provide the perfect solution for mini-bulk delivery programs. Complete and ready to use Chemical Feed Stations allow you to handle small amounts of liquids and other chemicals in a safer and more efficient manner than drums. The Chemical Feed Stations can be located close to your customer's use point, thereby eliminating the need for them to move and handle heavy drums and tote bins of hazardous materials, while at the same time eliminating the handling costs and inconvenient disposal of drums and one-way tote bins.



## **CUBETAINER™**

Snyder's new Cubetainer product line offers cost effective stackable fluid storage and dispensing solutions for Auto Service Shops, Quick Lube Stores, Fleet Operations and a variety of other industries.

## **C O R P O R A T E   H E A D Q U A R T E R S**

6940 "O" Street, Suite 100 • Lincoln, Nebraska • 68510

Phone: 402-467-5221 • Fax: 402-465-1220

**1-888-IBC-TOTE (888-422-8683) • [www.snyderibcs.com](http://www.snyderibcs.com)**

**email: [sales@snydernet.com](mailto:sales@snydernet.com)**

**OTHER MANUFACTURING LOCATIONS:** Marked Tree, Arkansas • Philippi, West Virginia • Chowchilla, California  
Mancelona, Michigan • Bensenville, Illinois • West Chicago, Illinois